

NOTE: The power cable to the Pandora unit must be arranged/secured below the fixing surface so as not to restrict the rotating mechanism.

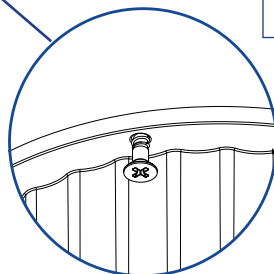

1. Unscrew and remove the locking ring from the PANDORA unit.
2. Place PANDORA into a Ø128mm hole.
3. Screw the locking ring onto PANDORA until the unit is secure in the surface.

Fitting PANDORA with screws

PANDORA with the inlay type grommet can be fixed to a surface via four screws without rear access being needed. The inlays will then cover the screw heads.

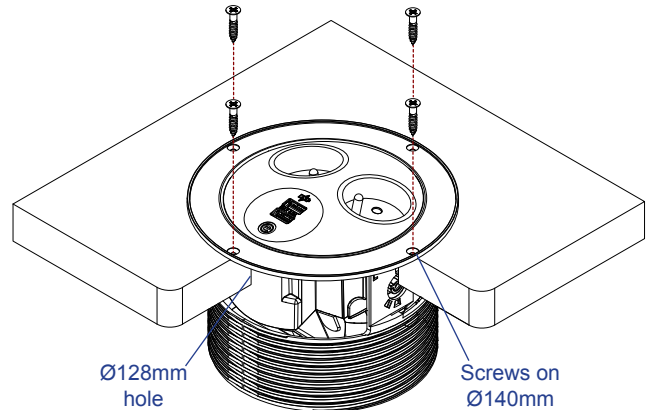

Fitting outer inlay

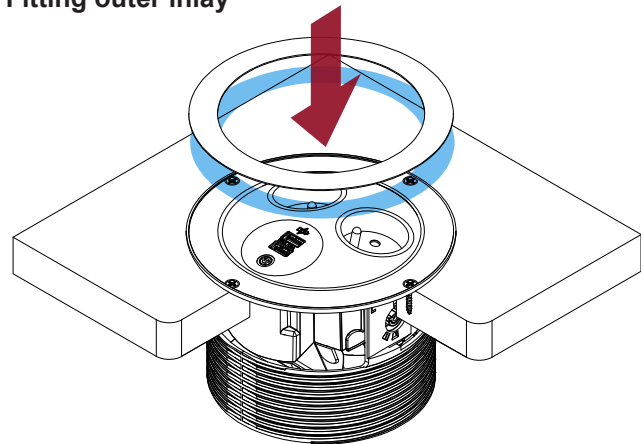

To fit the outer inlay, remove the VHB tape cover, align with the outer grommet, and then press down firmly.

When fitting a brushed stainless steel outer inlay, ensure that the grain follows the direction of the grain on the inner inlay.

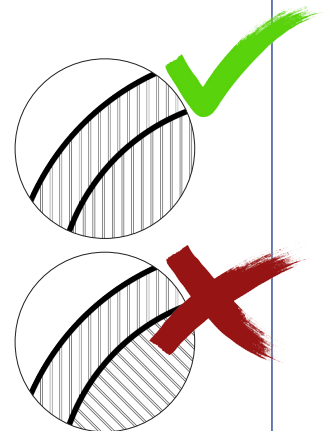

Queries / Questions / Fragen:
 +44 (0) 1924 367255

